

Bogdan Włodarczyk,
Krzysztof Kowalski

Department of Knitting Technology
and Structure of Knitted Products
Faculty of Material Engineering and Textile Design
Technical University of Łódź
ul. Żeromskiego 116, 90-543, Łódź Poland
e-mail: kjkowalski@p.lodz.pl

Analysis of the Process of Pulling a Thread Through a Friction Barrier Considering the Non-uniformity of Visco-Elastic Properties of Yarns and Their Random Changes

Abstract

Textile technologies are characterised by zones in which threads are stretched between elements of different machines and working elements of the same machine on which the drawn threads are displaced. The length of these zones is from several millimetres to several metres. The variability of tensions in the displaced threads is caused by technological conditions and the factors connected with the non-uniformity of the mechanical properties of threads. The mathematical modelling of forces presented in literature does not often consider the mechanical non-uniformity of the raw material and therefore only presents average values of the force without informing about the parameters of the value dispersion which is observed in real processes. The aim of this article is to attempt to evaluate the influence of the non-uniformities of the mechanical properties of yarns on the generation of forces acting in threads pulled through friction barriers and on their character. Broad ranges of thread speed values and the curvature radii of the barriers were accepted in our computer simulations. The model described in this article is a development of solutions described earlier.

Key words: visco-elastic thread, random irregularities, tensions, probabilistic model, stretching, drawing zone, friction barrier.

Designations used

F_0 , in cN – force stretching the thread before the friction barrier – preliminary tension of the thread;

F_1 , in cN – force stretching the thread behind the barrier;

C , C_1 , in cN – relative coefficients of the drawing rigidity during stretching, for the particular branches of the Zener model (values relating to relative deformations of the thread [1,21]);

C_{NL1} , C_{NL2} ... C_{NLn} , in cN – coefficients of relative drawing rigidity for particular elementary links of the thread (values relating to absolute deformations [1, 21]);

C_{EQ} , in cN – equivalent (substitute) relative coefficient of the drawing rigidity for a thread segment consisting of "n" links of a thread segment which is placed on the barrier (the equivalent value is representative for relative deformations [1, 21]);

η , in cNs – relative coefficients of dynamic viscosity;

L_0 , in m – length of an elementary link of the thread;

P , in m – curvature radius of the friction barrier;

α , in rad – encircling angle of the thread on the barrier ;

$L = \rho \cdot \alpha$ - length of contact between the barrier and thread;

ε - relative elongation;

v_t , in m/s – displacement speed of the thread;

v_ε - speed of relative deformations of the thread on the friction barrier;

t , in s – time;

a , n – experimental constants in the generalised friction rule [7];

b – number of elementary links of the thread which are in contact with the surface of the friction barrier;

k – number of links of the thread which should be displaced through the barrier in the algorithm.

Introduction

Values of the visco-elastic parameters of yarns are random variables which differ along the length of the thread, as the following authors reported in [3 - 13, 16 - 21].

Experimental works [22 - 26] indicated a considerable influence of the thread's speed and, at the same time, the speed of increase in the relative deformation of the thread on the values of forces. It can be observed that higher deformation speeds result in higher tensions than those caused by gradually slowly drawing. In the solutions presented in existing literature, the authors did not consider the influence of thread mass on its tension as being too small or insignificant. They considered the thread as a weightless body whose tension mainly depends on the rheological properties of the thread's matrix.

Notwithstanding the zones where free thread fragments are drawn, the dynamic stretching of threads on friction barriers also occurs in textile technologies. This especially concerns friction barriers with circular cross-sections characterised by a curvature radius and flat barriers with a short friction zone. The process of pulling threads on barriers is accompanied by forces created very rapidly, which increase in a short time, and deformation which takes place along the line of contact between the barrier and thread [7]. At these conditions, the relative elongation

increases of the thread along its contact with the barrier line causes the appearance of viscose resistance forces due to the visco-elastic thread properties assumed for the considerations.

The above-mentioned observations, which are also described in the literature cited above, give cause to develop a mathematical model [7] for the process of pulling a thread through a friction barrier which would consider the rheological yarn properties described.

The considerations described in [7] were based on a three-element Zener model (**Figure 1**) for which the dependency of the deformation ε , the stretching force F and time of force operation t , as well as rheological parameters C , C_1 , and η is described by the following differential equation:

$$F + \frac{\eta}{C_1} \cdot \frac{dF}{dt} = C \cdot \varepsilon + (C + C_1) \cdot \frac{\eta}{C_1} \cdot \frac{d\varepsilon}{dt} \quad (1)$$

which was used for deriving the dependences later described in this article.

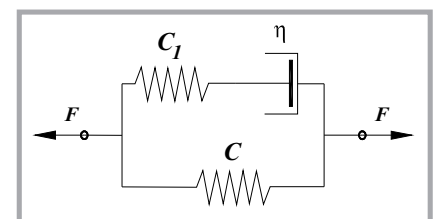

Figure 1. A three-element Zener model.

Within the scope of this work, the model mentioned-above was modified by adding random changing variability to the viscoelastic property parameters of yarns. Random modification of the rheological parameters of yarn was performed by the method used in works [1, 2, 28].

The basis for the considerations

Below are presented the assumptions and basic dependencies of the model described (according to [7]):

- The friction is described by the generalised form of the friction rule $T = aN^n$.
- The thread is considered as a weightless body, without mass.
- The thread is considered as matter with visco-elastic properties, for which the dependence between the relative elongation ε , the stretching force F_1 and the force operation time t is described by the three-element rheological Zener model.
- The deformation ε of the thread on the friction barrier is a result of the friction force.
- The speed of increase of the relative thread deformation, $d\varepsilon/dt = v_\varepsilon$, on the friction barrier is constant at a given speed of the thread pulled-through.
- The relaxation of the preliminary forces F_0 on the barrier is omitted.

The dependencies obtained on the basis of the assumptions mentioned above have the following form:

Thread tension behind the barrier:

$$F_1 = F_0 + C \cdot v_\varepsilon \cdot t + \eta \cdot v_\varepsilon \cdot \left(1 - e^{-\frac{t \cdot C_1}{\eta}}\right) \quad (2)$$

where:

$t = \rho \cdot \alpha / v$ – time of thread displacement within the encircling boundaries of the friction barrier, (3)

and the speed increase in the deformation of the thread segment which is in contact with the barrier surface is described by the following dependency;

$$v_\varepsilon = \frac{v \cdot F_0}{C \cdot \rho \cdot \alpha} \cdot \left[e^{\alpha \cdot a \cdot \left[\frac{\rho}{F_0}\right]^{1-n}} - 1 \right] \quad (4)$$

The above-presented dependencies include the rheological parameters of the

thread, the relative rigidities of drawing, C and C_1 , the viscose features of the thread matte determined by the relative dynamic viscosity coefficient and the geometrical parameters of the friction barrier, i.e. the length of the contact line l and radius of curvature ρ , as well as the influence of the velocity v of the thread pulled-through.

In the model interpretations presented in [7], the friction coefficient μ does not directly exist due to the assumption of the generalised friction rule $t = aN^n$. The value of the conventional accepted friction coefficient μ for a circular barrier can be determined on the basis dependency (5) where the value F_1 is obtained from dependency (2):

$$\mu = \frac{1}{\alpha} \cdot \ln \frac{F_1}{F_0} \quad (5)$$

According to [7], **Figure 2** presents an object schematic diagram of the value of friction coefficient μ as a function of the diameter of the friction barrier d . The author of [7] obtained these curves on the basis of the dependencies developed (2), (3), (4) and (5). In order to perform a comparative analysis additional to curve (a) which was calculate according to the proper model (equations 2 and 5), two other curves were drawn and presented in **Figure 2**. Curve (b) presents the value of the conventionally accepted friction coefficient μ , calculated for the dependency which only takes into account the dependency $T = aN^n$ ($v \rightarrow 0$, Howell-Lincoln model). However, curve (c) contains the difference between the above-mention model and represents the influence of the rheological properties of the thread; till now these have not been considered in model interpretation.

The author of [7] stated that, from the curves presented in Figure 2, we can conclude that an optimal range of the friction barrier diameters d exists for which the values of the resistance during the pulling of thread through the barrier are minimal. This optimal range for ρ is the result of superimposing the two processes, which are mutually opposite considering the direction of influence. One of them, which is connected with the real contact surface and is presented by curve (b), dominates on barriers with relative great radii ρ , whereas the second process (curve (c)) especially influences the phenomena occurring on the barrier and dominates quantitatively on barriers with

diameters d similar to that of the thread. This latter process is connected with relations which exist between the speed of increase in relative deformations, the viscose resistance, and relaxation of the forces acting in threads.

From the interpretation of the expression $\exp(-tC_1/\eta)$, which is responsible for the relaxation process of the forces, it can be concluded that these forces depend inversively exponentially on the time during which deformations occur, which means that they decrease with time. This time depends on the speed v of pulling the thread as well as on the geometrical parameters of the friction barrier and is equal to the time of displacing the thread through the friction barrier.

The comparison of the character of the experimental curves presented in [29] and shown in **Figure 3** with the model curve (a - in **Figure 2**) indicates that the

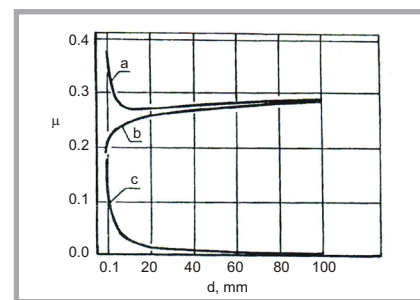

Figure 2. Dependency of the conventional accepted friction coefficient, according to the rheological model of a circular friction barrier, on the average diameter d of the barrier; the calculation parameters: $F_0 = 5$ cN, $v = 2$ m/s, $a = 0.38$, $n = 0.93$, $C = 2500$ cN, $C_1 = 4,500$ cN, $\eta = 2$ cNs.

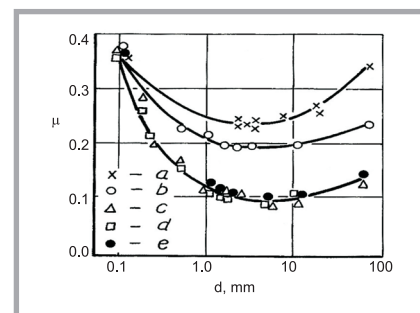

Figure 3. Changes in the friction coefficient of cotton yarn at different degrees of paraffin deposition as functions of the average friction barrier diameter according to Bühler and Häusler [28]; research conditions: cotton 20 tex, barrier - polished steel $\alpha = 180^\circ$, $v = 3.3$ m/s, $F_0 = 5$ cN; x - yarn without paraffin deposition, o - yarn with too little paraffin deposition, Δ - yarn with optimal paraffin deposition, □ - yarn with too high paraffin deposition.

theoretical model proposed mirrors the phenomena connected with pulling the thread for a broad range of friction barriers.

The theory developed in [7] indicates that, in the process of pulling a thread through a friction barrier, not only are the friction phenomena decisive, which take place in the contact region of the value of forces behind the barrier, but also the phenomena which occur in the thread matter.

Assumptions and theoretical basis of the considerations

In this work, an attempt was undertaken to develop a model to determine the influence of random changes in the relative coefficient of drawing rigidity on the average values of thread tensions behind a friction barrier, and on the value of the coefficient of variations of these tensions, which characterise the tension dispersion. In order to do this, the following assumptions were made:

- the thread pulled through the barrier, consists of short segments (links). Each of these segments is built as a Zener model (Figure 1, see page 78), and has different rheological properties defined by the coefficients C , $C_1, C_2, C_3, \dots, C_n; C_{1n}, C_{11}, C_{12}, C_{13}, \dots, C_{1n}$, all in cN, and the viscosity η , in cNs (Figure 4).
- Values of the coefficients C and C_1 for the subsequent links change randomly and have a normal distribution.
- The time of stretching a thread segment, which is displaced on the barrier, is equal to the time of displacing the segment through the barrier with a speed which is equal to the speed of the thread (dependency 3).
- The relation between the thread tension before and behind the barrier is described by equation (2), taking into account dependencies (3), and (4).
- The values of the substitute coefficients C and C_1 of the stretched thread segment are composed of n elementary links, which are actually in contact with the friction barrier and are determined by dependency (6).
- The transport of the thread is simplified in such a way that subsequent calculations of the stretching force are performed after exchanging the boundary segment, of the part of the thread which is placed on the barrier.

The segment which is directly before leaving the barrier is rejected, and at the same time the subsequent segment waiting before the barrier to enter the barrier zone is added (Figure 5).

- Before beginning the calculations the following parameters should be accepted:
 - Coefficients of variation for C and C_1 ,
 - Preliminary thread tension F_0 before the barrier of coefficients C and C_1 - the average values
 - Viscosity η of the thread matter,
 - Curvature radius ρ of the barrier,
 - Angle α of the thread encircling the barrier.

Calculation algorithm of forces in the thread pulled through a friction barrier

The calculation algorithm is presented in Figure 6.

The calculation of the actual value of the force stretching the thread is performed according to equation (2). Random modification of the average values of C and C_1 , which are taken by the program and accepted for calculation, is performed automatically by a computer using a special algorithm which considers the existing, normal distribution of the results and the assumed coefficient of variation. As a result of this action, we obtained a set

$$\frac{1}{C_{\Delta L, ZAST}} = \frac{1}{C_{\Delta L1}} + \frac{1}{C_{\Delta L2}} + \frac{1}{C_{\Delta L3}} + \dots + \frac{1}{C_{\Delta Ln}} = \sum_{i=1}^n \frac{1}{C_{\Delta Li}} \quad \text{and } C_{\epsilon ZAST} = C_{\Delta L, ZAST} \cdot L_0 \quad \text{similarly as in [1, 2, 28]} \quad (6)$$

Equation 6.

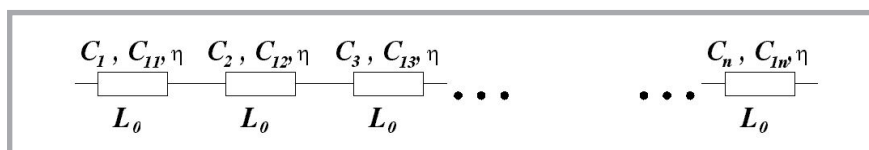

Figure 4. Thread model used in our calculations.

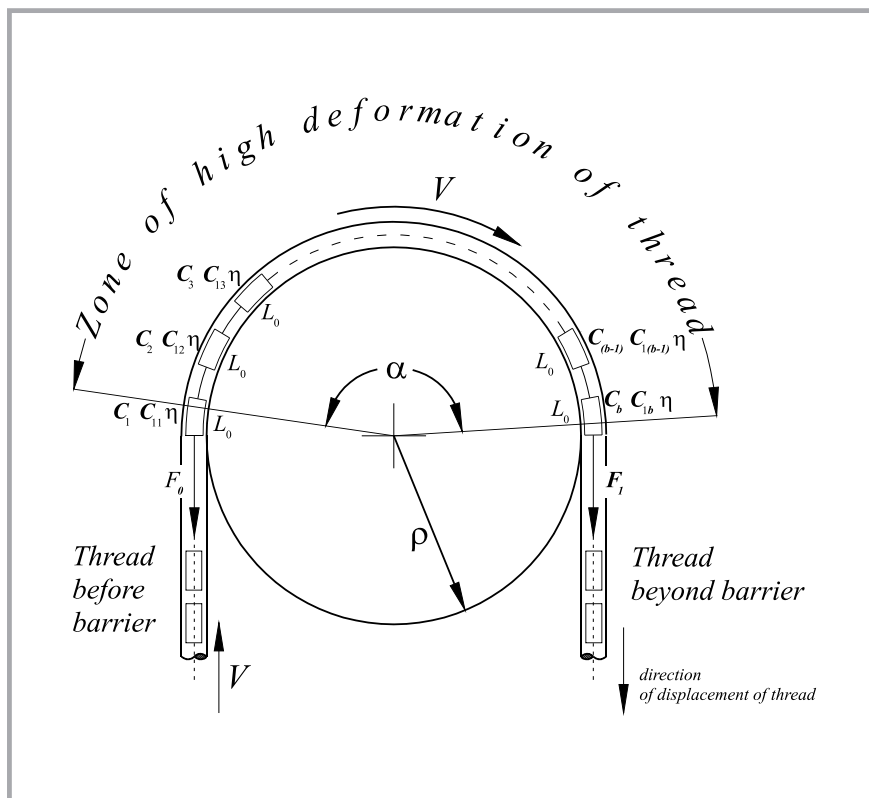

Figure 5. Model of the thread placed on the friction barrier accepted by the authors.

of values for C and C_1 which are subsequently used in the calculation.

The calculation algorithm realises the simplified transport of the thread through the barrier, which means that the subsequent calculation of the force stretching the thread behind the barrier is performed after exchanging the boundary elements of the thread segment which are in contact with the surface of the barrier.

After exchanging the links, the algorithm determines the substitute values of the coefficients C and C_1 according to the formula given in the assumptions, which is developed in [1, 2], and next calculates the value of the force behind the barrier according to dependencies (2), (3) and (4).

Results obtained from the model

In order to determine the simulation possibilities of the model developed by the authors, calculations were carried out accepting the following data: $F_0 = 5$ cN, $v = 2$ m/s, $a = 0.38$, $n = 0.93$, $C = 4,200$ cN, $C_1 = 3,800$ cN, and $\eta = 2$ cNs. The length of the elementary thread link was accepted as $L = 5$ mm. The calculations were carried out for barriers with radii of 0.5 mm, 1.0 mm, 2.0 mm, 5.0 mm, 10.0 mm, 20.0 mm, 30.0 mm, 50.0 mm, and 100.0 mm. The values of the assumed coefficient of variation of the relative drawing rigidity of C and C_1 were equal to 25%. Histograms of the sets of random numbers used are presented in *Figures 7.a* and *7.b* (see page 82) as examples. An example of a histogram of the calculation results is presented in *Figure 7.c* (see page 82).

From the results of simulation, we obtain differentiated values of the thread tension behind the barrier, which are presented in *Figure 8* as an example. As can be seen, the curves of the momentary values obtained of the thread tension behind the barrier have a variable stochastic character similar to those obtained in experiments. The variability of the force curves obtained are strongly dependent on the curvature values of the barrier.

In conclusion we can state that the model of pulling a thread through a friction barrier, implemented by probabilistic elements, allows to generate momentary values of the thread force behind the friction barrier and to explain one case of thread force variability in textile technologies.

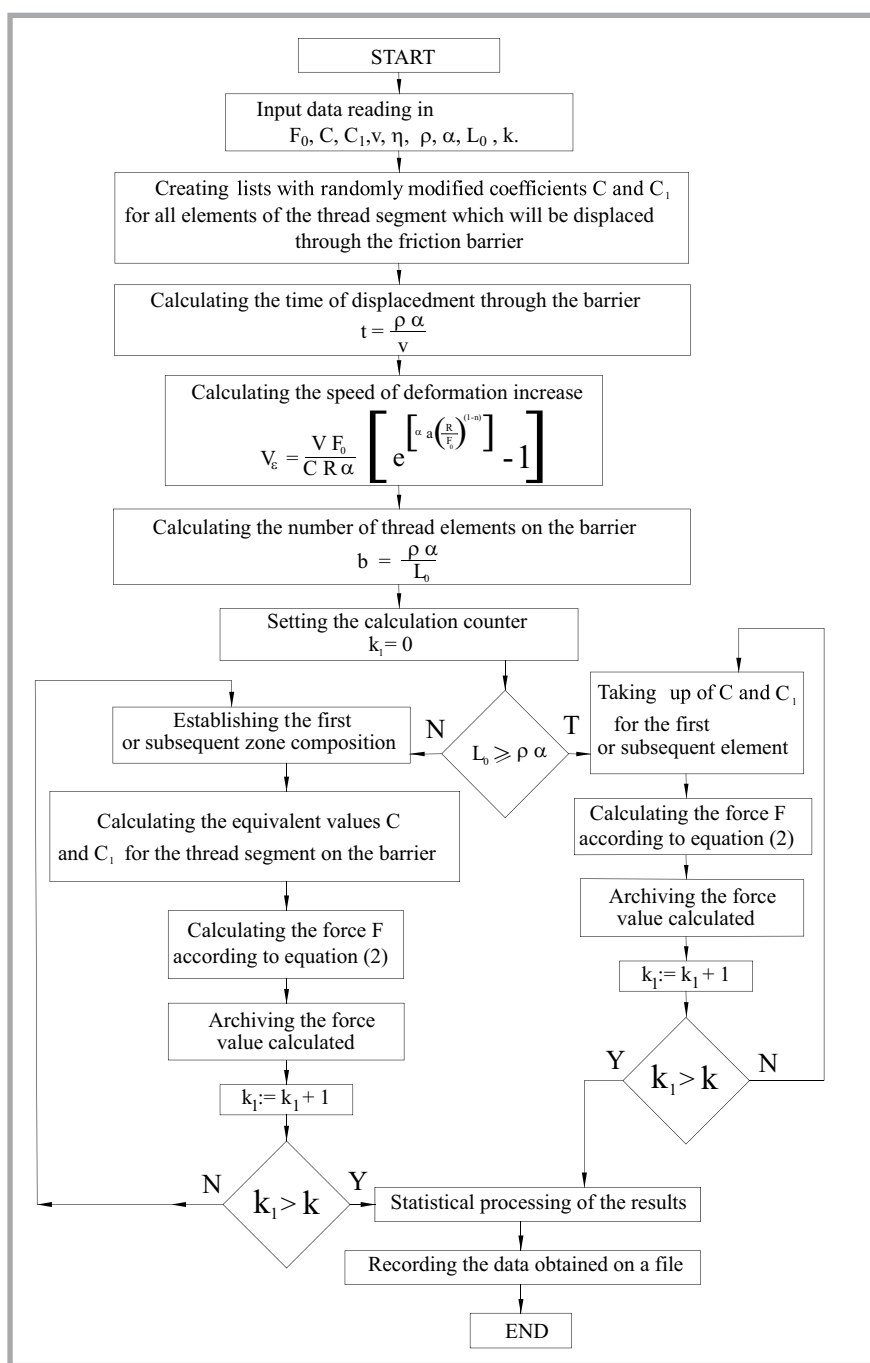

Figure 6. Calculation algorithm of a discrete model of the probabilistic process of pulling a thread through a friction barrier.

Analysis of results obtained by calculations

In order to determine the character of changes in the thread tension behind the friction barrier, simulation calculations were carried out in accordance with the model developed for broad ranges of the barrier curvature radius and the speed of pulling the thread through the barrier. The following input data were used for calculations: $F_0 = 5$, $A = 0.38$, $n = 0.93$, $C = 2,500$, and $C_1 = 4,500$ all in cN, and $\mu = 2$ cNs. It was assumed that the length of the elementary link of the thread is

equal to $l_0 = 3$ mm. The calculations were carried out for barriers with a curvature radius within the range of 1.0 - 250 mm and the speed of pulling the thread within the range of 0.1 - 25.0 m/s. The coefficient of variation for the relative drawing rigidity of C and C_1 were accepted as 30%. Different sets of random numbers for the coefficients C and C_1 were used in order to prove that the random increase in the coefficient C would not be connected with the increase in coefficient C_1 . Random changes in the values of C and C_1 were mutually independent.

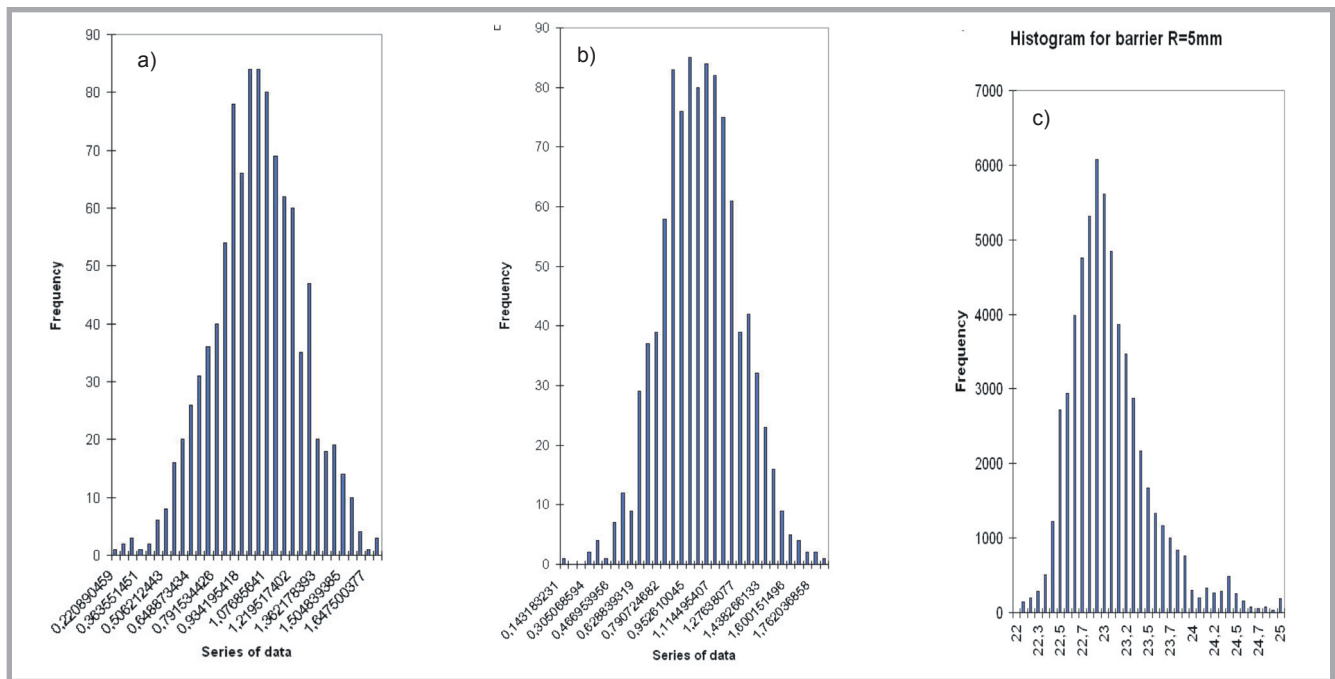

Figure 7. Examples of histograms: a and b - histograms for sets of random numbers used to calculations; a - for the coefficient C , b - for the coefficient C_1 ; c - for one of the curves presented in Figure 6 representing the thread tension behind the barrier.

A diagram of the average values of the tension behind the barrier with dependence on the curvature radius of the barrier and speed of pulling the thread through the barrier are presented in **Figure 9**.

From this diagram we can observe that, at low speeds of pulling the thread, the tension behind the barrier increases with

a rise in the curvature radius, which provides about the majority of phenomena connected with static friction during the contact of thread with barrier surfaces. This is in accordance with the theory presented by the author of [7] and visualised by the curves in **Figures 2 and 3** (see page 79).

At greater thread speeds we can observe the majority of the phenomena are connected with the dynamic stretching of thread mater. When the thread speed is about 0.7 m/s or above, the average values of the thread tension behind the barrier intensively decreases with a rise in barrier curvature values. This drop is

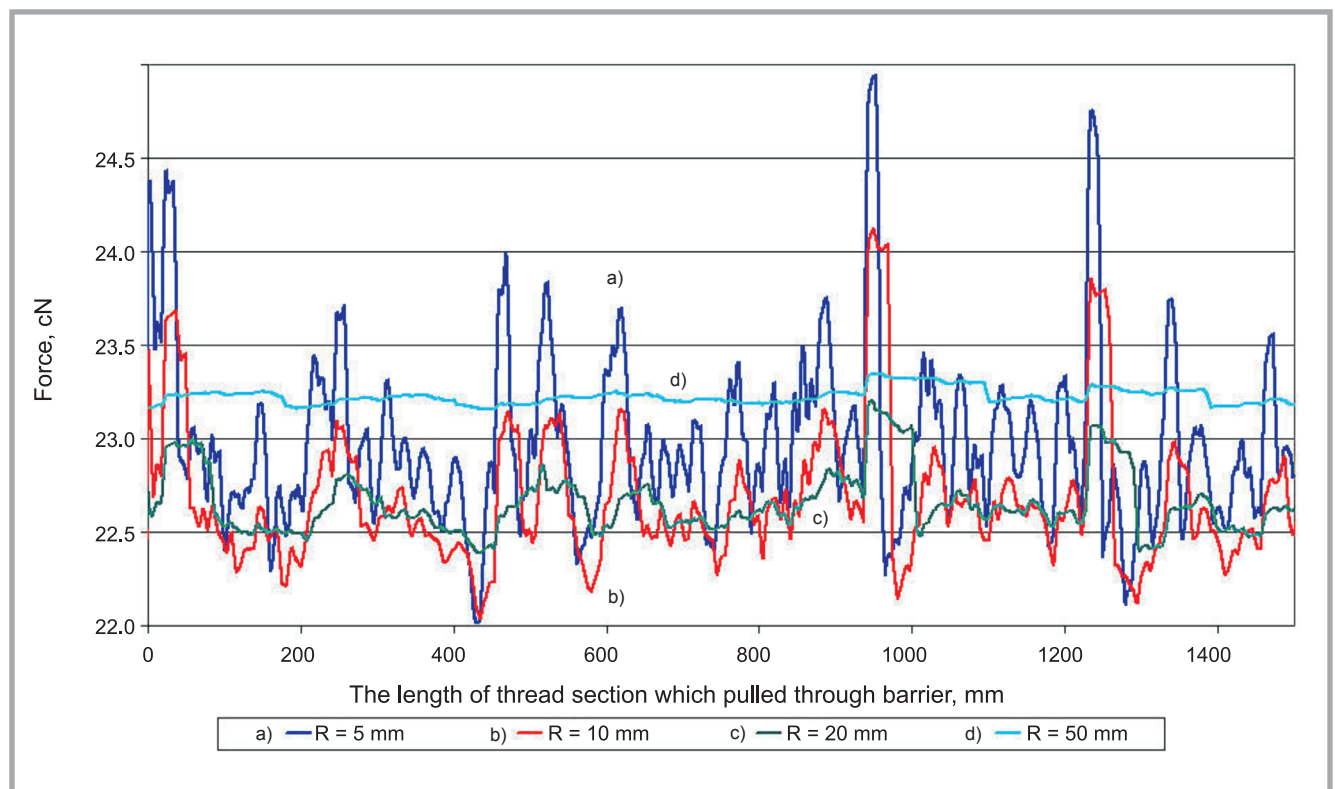

Figure 8. Curves of the thread tension behind the friction barrier for barriers with different curvature radii.

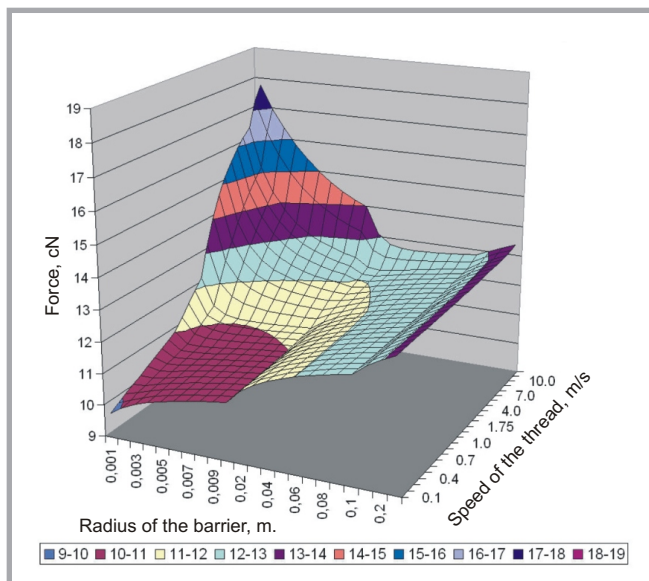

Figure 9. Dependence of the thread tension behind the friction barrier on the barrier curvature radius and speed of pulling the thread through the barrier.

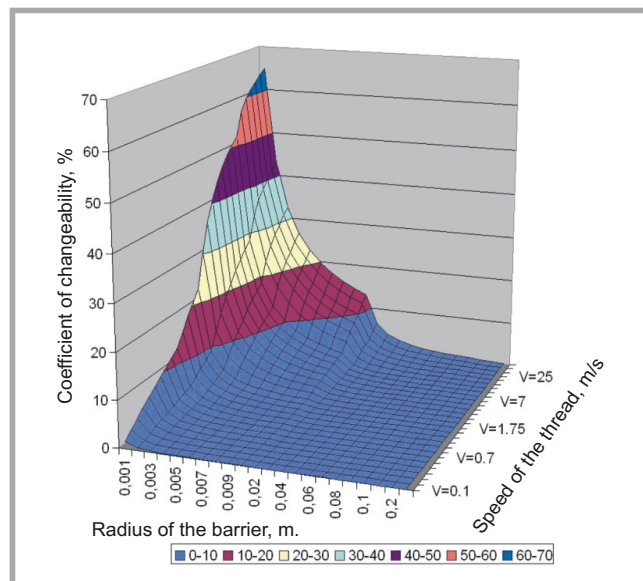

Figure 10. A diagram of the coefficient of variation for thread tensions behind a friction barrier with dependence on the curvature values of the barrier and the speed of pulling the thread.

intensive for barriers with a small radius within the range from zero to about (1 - 2) cm. This is connected with the process of thread mater relaxation which takes place during the thread deformation on the barrier. For curvatures with greater radii, we observed a slow increase in the average tension with a rise in the barrier radius.

An increase in the speed of displacing the thread on the barrier causes an intensive increase in the tension behind the barrier, but only for barriers with a small radius. Massive barriers, with a large radius do not cause a significant increase in the tension with the an increase in thread speed. It occurs, therefore, that differences in the speed of increases in relative deformation are small in relation to the particular speeds of thread displacement .

From the above - mentioned observations, it can be concluded that, for typical speeds of pulling the thread, which are used in technological textile processes (from about 0.8m/s to 5 m/s), a certain

range of values for the barrier curvature radius exists, for which the average tension values behind the barrier are minimal; this means that this range of barrier radii is optimal from the point of view of the minimum value of forces.

A diagram of the coefficient of variation for the average tensions presented in **Figure 9** is shown in **Figure 10**, with dependence on the barrier radius and thread speed.

From the diagram in **Figure 10**, it can be concluded that a small curvature radius of the barrier and high thread speeds cause large thread tension variability behind the barrier. Barriers with a large curvature radius smoothes the curves of the thread tension changes, and even more intensively at higher speeds of thread displacement.

Comparison of the results show that the simulation indicates a decrease in the coefficient of variation of the thread tension

behind the barrier with an increase in the curvature radius of the friction barrier. This indicates that friction barriers with relatively large diameters produce values of forces with smaller variability. However, it should be mentioned that the simulation concerns only model yarns with similar rheological properties.

Friction barriers with small diameters significantly increase the average thread tension value (**Figure 11**) and also increase there ranges of variability. Curvature radii greater than the optimal cause a new increase in the value of the average forces in threads, but decrease the range of variability of these forces. This is illustrated by the curve in **Figure 11**, which shows the average values of thread tensions behind the barrier.

For frictions barriers with a small diameter, the forces in the thread rise when the relaxation process is slower than the increase in tensions. This process is the cause of amplifying the variability of tensions connected with the variability in the visco-elastic properties of thread mater.

Conclusions

- The model for the process of pulling a thread through a friction barrier implementes by probalistic elements allows the generation of momentary values of the thread tension behind the barrier and clears one of the causes of thread tension variability observed in textile technological processes.

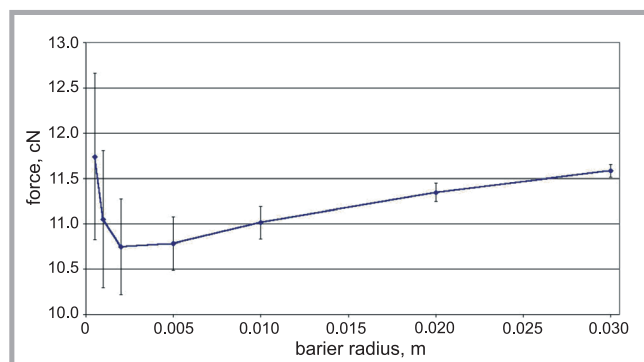

Figure 11. Changes in thread tension behind the friction barrier with dependence on its radius.

- At relatively small speeds of pulling the thread through the friction barrier ($v = 0.1 - 0.7$ m/s), the average values of forces increase with an increase in the barrier radius, as the phenomena connected with the generalised friction rule $T = aN^n$ comprise the majority of phenomena. Furthermore, the coefficient of variation for the average values of forces indicates low values.
- The values of forces in the threads rise with an increase in the speed of pulling the thread, and at the same time the intensity of the force increase is higher when the barrier diameter is smaller. In such conditions the majority of the dynamic component (the component C in **Figure 2**) is observed, which describes the relations which take place between the speed of increases in the relative deformations, viscose resistance and the relaxation of forces in the threads.
- The optimum value of the friction barrier diameters, which assure a minimum value of the forces in the threads, increases with the rising speed of pulling the thread.
- The value of the coefficient of variation of forces in threads increases with an increase in the speed of pulling the thread through the friction barrier and the decrease in the barrier diameter. This is due to:
 - the formation of the value of the substitute coefficient of drawing rigidity of the thread segment being placed on the friction barrier according to equation (6), whose value depends on the number of thread links which are placed on the barrier (a greater number of links causes a lower value of the substitute coefficient of drawing rigidity of the thread segment which is placed on the barrier);
 - the decreasing time periods of tension relaxation of the thread segment pulled through the friction barrier.



References

1. Włodarczyk B., Kowalski K.; A Discrete Probability Model of Forces in Yarns Transported Through the Drawing Zone. *FIBRES & TEXTILES in Eastern Europe* April / Juni 2006, Vol. 14, No. 2 (56).
2. Włodarczyk B.; 'Estimation of irregularities of mechanical properties of threads on the basis of an analysis of forces in a thread in a short drawing zone (in Polish)', Ph.D. Thesis, Faculty of Textile Engineering and Marketing, Technical University of Łódź, Poland, 2007.
3. Knapton J. F., Munden D. L.; A Study of the Mechanism of Loop Formation on Weft-Knitting Machinery. *Text.Res.J.* 12 (1966), pp. 1072-1091.
4. Knapton J.F.; *The Dynamics of Weft-Knitting*. *Text. Res. J.* 9 (1968) pp. 914-924.
5. Aisaka N.; *Mathematical Considerations of Weft-Knitting Process*. *J. Tex. Mach. Soc. Japan* 3 (1971) pp. 82-91.
6. Kowalski K.; 'Modelling of the process of pulling threads through friction barriers – physical model of pulling threads through friction barriers (in Polish)', *Przegląd Włókienniczy*, vol. 41, Nr. 4, 1987, pp. 163–166.
7. Kowalski K.; 'Analysis of the rheological model of the process of pulling threads through friction barriers (in Polish)', vol. 41, Nr. 6, 1987, pp. 226–229.
8. Kowalski K.; *Modellierung der Faden-Festkörper-Reibung*. *Melliand Textilberichte* 3/1991 pp. 171-175.
9. Kowalski K.; 'Identification of dynamic forces in threads on rib knitting machines on the basis of computer simulation and digital measurement technique (in Polish)', *Zeszyty Naukowe (scientific letters of Technical University of Łódź, Poland)*, Nr. 613, 1991.
10. Bauer H. J.; *Positive Fadenzuführung an Strickmaschinen – der Schlüssel zur Gestrickqualität, Maschen-Industrie* 46 (1996) 6, pp. 475-479,
11. Wunsch I., Pusche Th., Offermann P.; *Fadenzuführung an Runstrickmaschinen und eine neue Art Prozessdarstellung*. *Melliand Textilberichte* 5/1999 pp. 388-392.
12. Żyliński T.; *Nauka o włóknie*. Warszawa WPLiS 1958.
13. Urbańczyk G.; *Fizyka włókna. Fizyczne własności włókien*. WNT, Warszawa 1974.
14. Ryklin D. B., Rineisky K. N., Kogan A. G.; 'Computer simulation of the drawing process (in Polish)', *Proceedings of the 6th International Scientific Conference IMTEX 2000, Łódź, Poland, 5–6 June 2000*.
15. Żurek W.; *Struktura liniowych wyrobów włókienniczych*. WNT, Warszawa, 1989
16. Bauer A., Winkler F.; *Dynamische Zugprüfung von Faden, IV Hystereischleife*. *Faserforsch und Textiltechnik* 16, 1965, 4, pp. 304 – 312. – 23
17. Bauer A., Winkler F.; *Dynamische Zugprüfung von Faden, V Die Dämpfung*. *Faserforsch und Textiltechnik* 16, 1965, 8, pp. 382 – 387. – 24
18. Bauer A., Winkler F.; *Dynamische Zugprüfung von Faden, VI Phasenwinkel und Verlustwinkel*. *Faserforsch und Textiltechnik* 26, 1965, 9, pp. 456 – 463.
19. Nitzche K., Bauer A., Winkler F.; *Relaxationsuntersuchungen an polymeren Festkörpern unter Aspekt der experimentellen Systemanalyse*. *Forschung und Textiltechnik* 26, 1075, 11, pp. 527 – 532.
20. Szosland J., Czołczyński M.; 'Propagation speed of a tension impulse in threads (in Polish)', *Przegląd Włókienniczy*, vol 27, Nr. 11, 1973, pp. 527–532.
21. Offermann P., Schafer J., Schubert E.; *Zur Theorie und Praxis bei der Fadenverarbeitung insbesondere in der Strickerei*. *Beilage 2/1979 zu den „Information Trikotagen und Strümpfe“*, VEB Wissenschaftlich – Technische Zentrum Trikotagen und Strümpfe, Limbach – Oberfrohna. – 28.
22. Lewiński J.; 'Dynamic tension threads during warping (in Polish)', Ph.D. Thesis, Technical University of Łódź, Poland, 1975.
23. Rogoza I. W., Beskosto W.; 'Experimental determination of thread tensions (in Russian)', *Tekst. Prom.*, vol. 29, Nr. 6, 1969, pp. 42–45.
24. Więźlak W., Nowak R.; 'Measurements of the static and dynamic tensions of sewing threads in the process of sewing (in Polish)' *Zeszyty Naukowe Politechniki Łódzkiej, Włókiennictwo (scientific letters of Technical University of Łódź, Poland)* p. 16, (1967).
25. Fieles – Kahl N., Helli I.G.; *Zusammenhänge zwieschen Luffeuchte, Temperatur und den Reibungskoeffizienten von Garnen*. *Textil Praxis* 21, 5 & 6 (1966).
26. Garbaruk W. N.; *Influence of the thread speed on its tension (in Russian)*, *Izw. WUZ. Tex. Legk. Prom.* Nr. 1, 1963, pp. 158–161.
27. Bland D. R.; *The Theory of linear Viscoelasticity*. Pergamon Press 1960.
28. Włodarczyk B., Kowalski K.; 'Discrete Probabilistic Model of Forces in a Thread with Visco-elastic Properties transported Through a Drawing Zone', *Fibres & Textiles in Eastern Europe* 2008 16(1) pp. 44-49.
29. Bühler G., Häussler W.; *Die Garnereibung bei unterschiedlichen Reibkörperdurchmessern und ihre Auswirkung beim Strickvorgang*. *Textil Praxis* 33, 2 (1978), pp.145-146.

Received 20.07.2007 Reviewed 11.03.2008