

# Effect of Antimicrobial Air Filter Treatment on Bacterial Survival

## Abstract

Woven air filters made of polypropylene were examined for bacterial survival. The test strains belonged to gram-positive and gram-negative bacteria. An antimicrobial agent, silver nitrate ( $AgNO_3$ ), was added to the filtering material after the production cycle and tested for its ability to prevent microorganisms from filter colonisation. Silver emission from the filtering material was also tested. It was found out that antibacterial filter treatment resulted in an evident reduction in living bacterial cells. The presence of silver ions in the air surrounding the incubation column was established.

**Key words:** polypropylene air filters, antimicrobial treatment, silver nitrate, bacterial survival, microbial colonisation.

present in indoor air comes from the air-handling system. Hugenholtz and Fuerst found out that even in an installation that was kept clean, the amount of bacteria even reached  $10^7$  cfu/ml (in drain pan water) [1]. The sump water of an evaporative condenser contained  $10^5$  cfu/ml despite biocide treatment. There are many studies that confirm the presence of living bacteria and fungi in air filters [1 - 6]. Apart from harmless microorganisms, there are many pathogenic species found in filters, the most dangerous bacterial species among which are *Pseudomonas aeruginosa* and *Legionella pneumophila*. The fungal pathogens isolated from air filters are as follows: *Alternaria* spp., *Aspergillus* spp., *Aureobasidium pullulans*, *Chaetomium* spp., *Cladosporium* spp., *Fusarium* spp., *Mucor* spp., *Penicillium* spp., *Phoma* spp., *Rhizopus* spp., *Scopulariopsis* spp., and *Ulocladium* spp. [4]. Most of them produce mycotoxins which are dangerous to human health. Certain strains are even able to produce 8 types of mycotoxins, which are usually located inside or on the surface of spores [7]. Inhaled mycotoxins damage the immune system and, in consequence, increase the risk of cancerous diseases. They are also harmful to the lungs and cause irritation of the skin and eyes. Other compounds produced by fungi that have an immunotoxic effect are glucans and VOC. Bacterial cells or their fragments present in inhaled air may also cause health problems. This concerns living cells of pathogenic bacteria, for example *Staphylococcus aureus*, *S. haemolyticus*, *Mycobacterium tuberculosis*, and *L. pneumophila*. Pathogenic bacteria present in the air mostly cause lung or skin diseases. The presence of gram-negative bacteria is especially dangerous as they are known to produce endotoxins, which occur in the outer membrane of certain gram-negative bacteria. They are lipopolisaccharide

complexes which are an integral part of the bacterial cell wall. Endotoxins are released into the surrounding environment during active cell growth or after its breakdown. When entering the airways, they cause acute and toxic inflammation of the lungs [8].

To reduce bacterial growth in air filters, not only special care and HVAC installation unit maintenance in a clean state is needed. It seems that it is necessary to introduce antimicrobial agents which prevent bacterial growth in filtering material, thereby reducing the level of biocontamination in the treated air.

The aim of this study was to determine the influence of the antimicrobial agent selected - silver nitrate ( $AgNO_3$ ) on bacterial survival in polypropylene air filters under favourable temperature, humidity and nutrient availability.

## Materials and methods

P1 woven filters, which are hydrophobic and made of polypropylene, both unused and used, were the test material. The Maximal Allowable Concentration for the P1 filters was no lower than  $2\text{ mg/m}^3$ . The maximum filtration rate with NaCl as the test aerosol was 20%, and the maximum resistance of flow equalled 210 Pa when the air stream equalled  $95\text{ dm}^3/\text{min}$ . Under laboratory conditions the filters received antimicrobial finishing after the production process. Three chemicals were chosen to verify their activity against bacteria: silver nitrate, potassium iodate and hydrated sodium tetraborate. The agar diffusion method was applied to determine their impact on bacterial growth. Five bacterial strains were used in this study: *Micrococcus luteus*, *M. roseus*, *Bacillus subtilis*, *Pseudomonas*

## Introduction

HVAC (Heating, Ventilating and Air Conditioning) systems are designed to create the comfort climate conditions of indoor air, i.e. optimum temperature, humidity and a low number of microorganisms. The outdoor air pollution and insufficient hygiene of an HVAC installation often results in the low quality of indoor air. The units of the HVAC system most susceptible to microbial colonisation are those where moisture and nutrients are present i.e. cooling towers, cooling coils, air filters and duct works. The WHO estimated that 50% of the biological contamination

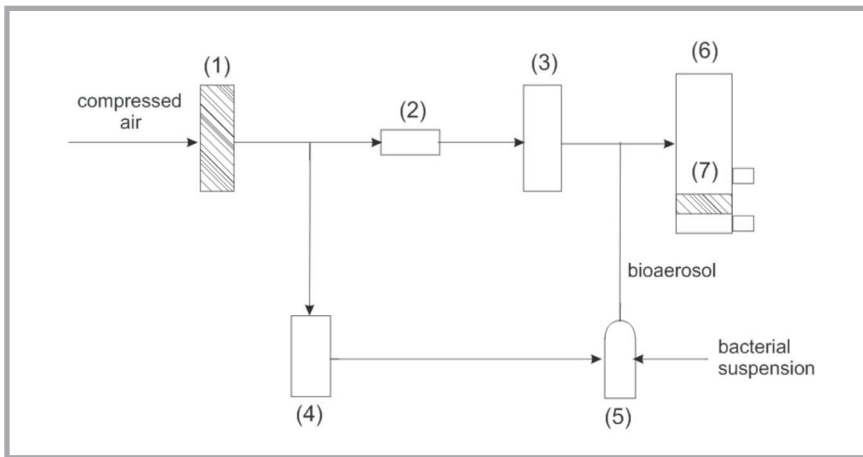

**Figure 1.** Experimental setup used in the nutrient broth aerosol and bioaerosol application on air filters.

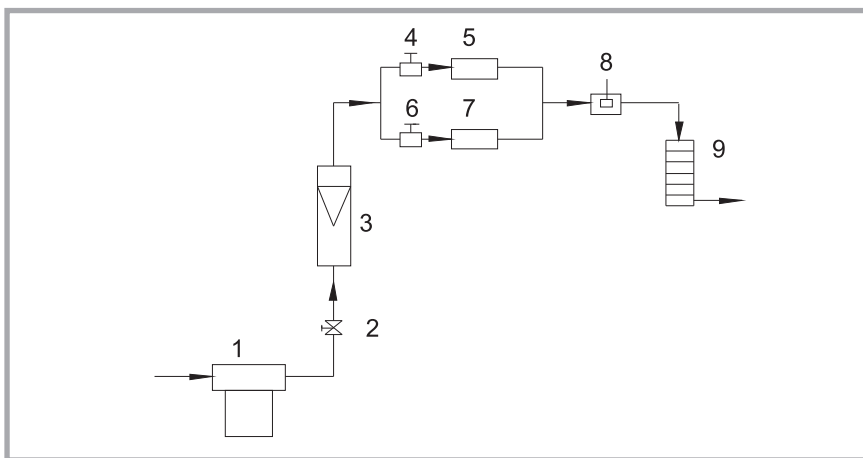

**Figure 2.** Experimental setup applied to test the effectiveness of the air filter treatment against bacterial development.

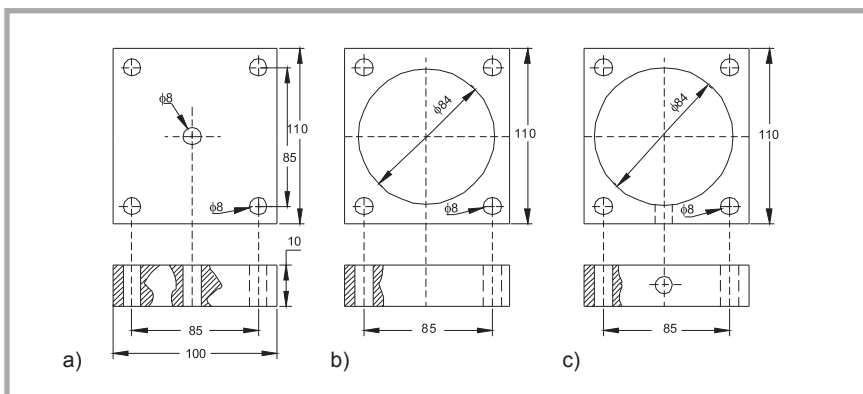

**Figure 3.** Elements of the incubation column: a) top plate, b) plates placed between the top and bottom plates, c) bottom plate.

*luteola* and *P. putida*. Bacterial suspension in sterile water was spread out on an agar plates. After that, paper disks were placed on and moistened with solutions of the three antimicrobials. The chemical compounds diffused radially from the paper disks into the agar. The inhibition capacity of each solution was estimated after 48 h incubation at 26 °C. The circu-

lar inhibition zone (no bacterial growth observed) indicated the antimicrobial activity of the chemical. It was observed that only silver nitrate inhibited bacterial growth within the range of the concentration from 0.01 to 0.0001 M. Based on the results of the experiment, silver nitrate was chosen for further experiments.

## Antimicrobial post production finishing

With this end in view, the following mixture was prepared: ethanol 95% - 95 ml, glycerin - 3 ml, and an antimicrobial component: silver nitrate - 2 ml. Three solutions of silver nitrate were tested: 0.01 M, 0.005 M and 0.007 M. Disc-shape samples (58 cm<sup>2</sup>) were cut from the filters and sterilised in UV light. After that, 10 ml of the mixture was applied on the surface of each filter, which were left to dry at room temperature. The final concentration of the silver nitrate on each filter was  $2.0 \times 10^{-6}$  M (0.132 mg Ag),  $1.4 \times 10^{-6}$  M (0.066 mg Ag) and  $1.0 \times 10^{-6}$  M (0.047 mg Ag), respectively. Afterwards, in order to simulate filter wear, the samples were aspirated with a nutrient broth. The experimental setup is presented in **Figure 1**. The main element was a filtration column (6) where air filters (7) were placed. Compressed air was pre-filtered (1) and divided into two streams, one of which passed through a pressure reductor (2) and rotameter (3), and the second one - through an air flow regulator (4) to an aerosol generator - a Collision nebuliser (5). The air flow rate was adjusted to 360 l/min. Aerosolised particles of the nutrient broth or bacterial cells (bioaerosol) entered the filtration column together with the air stream passing through the rotameter. The microbial suspension or nutrient broth entered the collision nebuliser at a flow rate of 30 ml/h. The aerosol was dried in a cylindrical vessel, diluted, and finally dosed to the filtration column.

## Microbial growth on air filters

Bacterial aerosol was dosed to filter samples in the same set up used in the case of the nutrient broth application (**Figure 1**). After that, the filters were placed in the incubation column (9), which was the principal element of the second experimental setup (**Figure 2**). Filtered (1) compressed air passed the regulation valve (2) and rotameter (3). The column contained five test filters at the same time. To support bacterial growth on the filtering material, the relative humidity of air passing through the incubation column (9) ranged between 70 - 80% (unused and untreated filters) and 80% - 86% (treated and used filters). To regulate the air humidity, a desiccator (5) and scrubber (7) were installed parallel to each other. A termohygrometer (8) was installed to control the air temperature and humidity. The air flow rate

through both elements was adjusted by means of two valves – 4, 6.

Then the air stream was directed to the incubation column, where disc samples of the filters were placed. The test filters were interspersed with filters made of glass fibres to prevent bacterial migration in the column from a higher placed filter to other ones. Elements of the column were made of plexiglass. There were single square plates with a central circular hole of 84 mm diameter. The filters and plexiglass plates were placed alternately and joined by means of four screws. The top plate was equipped with a small central hole which was an inlet for humid air, and the bottom plate had a hole in the side wall which was an outlet for air (**Figure 3**). Under the bottom plate there was an additional element with only 4 holes for screws.

Five bacterial strains were used in the study: *Micrococcus luteus*, *M. roseus*, *Bacillus subtilis*, *Pseudomonas luteola*, *P. putida*. *M. luteus*, *M. roseus* and *B. subtilis* are gram-positive bacteria, other strains – gram-negative. One of the test strains, *Bacillus subtilis*, was of the spore forming type. The different morphology of the bacterial colonies belonging to each strain enabled to estimate the amount of bacteria by means of the culture method.

The samples of unused and untreated filters were inoculated either by the bacterial aerosol containing *M. roseus*, *P. putida* and *B. subtilis* or by *M. luteus* exclusively. The samples of used and AgNO<sub>3</sub> treated filters were inoculated either by the mixed bioaerosol containing *M. roseus*, *P. luteola* and *B. subtilis* or by *M. luteus*. After that the filters were placed in the

**Table 1.** Parameters of the incubation of unused and untreated filters.

Parameters/Experiment	Experiment 1	Experiment 2
Test strains	<i>M. luteus</i>	<i>M. roseus</i> , <i>P. putida</i> , <i>B. subtilis</i>
Relative humidity, %	70	80
Temperature, °C	20.9 – 21.8	17.0 – 21.2
Incubation time, days	11	34

**Table 2.** Parameters of the incubation of used and treated filters.

Parameters/Experiment	Experiment 1	Experiment 2
Test strains	<i>M. luteus</i>	<i>M. roseus</i> , <i>P. luteola</i> , <i>B. subtilis</i>
Relative humidity, %	80 – 86	80 - 85
Temperature, °C	20.4 – 22.0	18.6 – 21.1
Incubation time, days	14	9

incubation column. The incubation conditions are presented in **Tables 1** and **2**.

Filters were removed from the column every 2 - 3 days or 6 - 7 days, depending on the variant of experiment. The number of living cells was estimated by the culture method. Each filter was placed in 100 ml of 0.08% sterile sodium pyrophosphate solution with the addition of 0.0005% polyoxyethylenesorbitan monooleate (Tween 80). Bacteria were washed out within 40 minutes, placed on nutrient agar and incubated at 26 °C for 2 days. The amount of bacteria was given as cfu/cm<sup>2</sup>. The same procedure was applied to estimate the amount of bacteria at the beginning of the experiment (t<sub>0</sub>).

#### Silver nitrate assay

The concentration of silver ions emitted from the incubation column (within a radius of about 30 cm) within the first 30 minutes after the air flow began and that of silver dissolved in the sodium pyrophosphate solution during the bacteria washing-out process was estimated by Graphite Furnace Atomic Absorption Spectrometry (GF AAS). Air samples

were taken by impingement into liquid (sterile demineralised water).

## Results

### Microbial growth on air filters

The unused and untreated filters showed growth for all four bacterial strains tested.

The results of the experiments are presented in **Figures 4** and **5**. In the case of gram-positive bacteria *M. luteus*, the number of cells decreased 25× at the beginning of the experiment. Afterwards their amount increased, reaching the initial value (**Figure 4**). Within 34 days of the incubation of the 3 other bacterial strains (*M. roseus*, *B. subtilis*, *P. putida*), their amount fluctuated. During the first 13 days, it decreased, after which the amount of *B. subtilis* stabilised at the level of 10<sup>3</sup> cfu/cm<sup>2</sup> and *P. putida* at 10<sup>2</sup> cfu/cm<sup>2</sup>. The amount of *M. roseus* gradually decreased (**Figure 5**). The used filters treated with AgNO<sub>3</sub> at a concentration of 2.0×10<sup>-6</sup> M inhibited *M. luteus* growth by 100%. The two other concentrations: 1.4×10<sup>-6</sup> M and 1.0×10<sup>-6</sup> M caused a

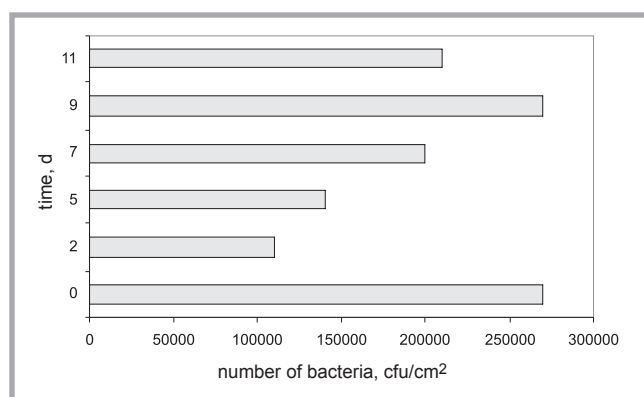

**Figure 4.** Changes in the amount of *M. luteus* in unused and untreated filters within an 11-day incubation.

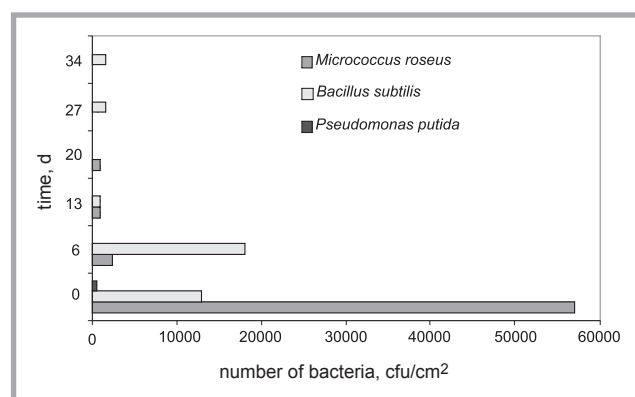

**Figure 5.** Changes in the number of three bacterial strains: *M. roseus*, *B. subtilis*, *P. putida* in unused and untreated filters within a 34-day incubation.

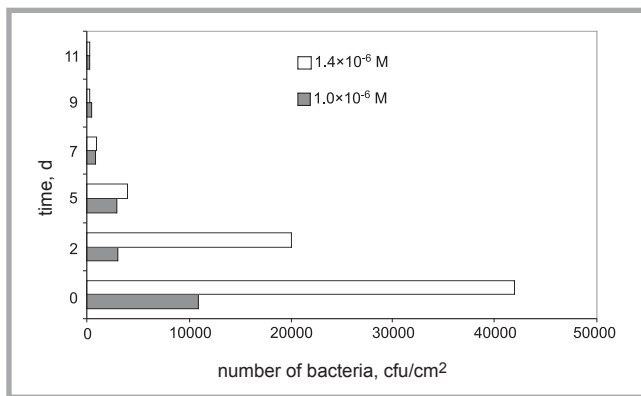

**Figure 6.** Changes in the amount of *M. luteus* in used and AgNO<sub>3</sub> treated filters at a concentration of 1 × 10<sup>-6</sup> M, and 1.4 × 10<sup>-6</sup> M.

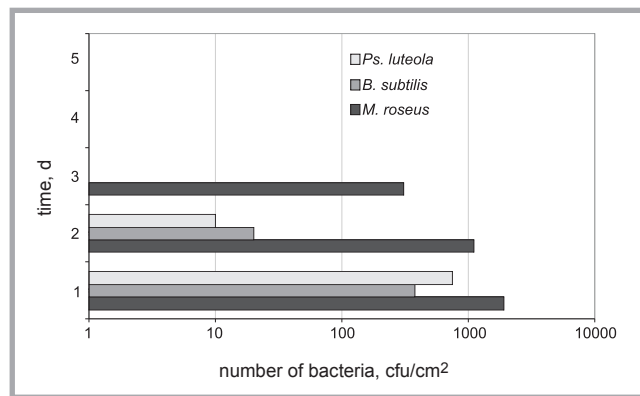

**Figure 7.** Changes in the amount of three bacterial strains: *M. roseus*, *B. subtilis*, *P. luteola* in used and AgNO<sub>3</sub> treated filters (1.4 × 10<sup>-6</sup> M).

permanent decrease in the number of bacterial cells after 11 days of incubation (Figure 6). In the case of *M. roseus*, *B. subtilis* & *P. luteola* in the filters treated with 1.4 × 10<sup>-6</sup> M AgNO<sub>3</sub>, a total decline of all bacterial strains was found within 7 days (Figure 7).

#### Silver nitrate assay

The results of the chemical analysis indicated that silver was emitted from the incubation column with a concentration of 0.00017 mg/dm<sup>3</sup>. During the washingout process in the sodium pyrophosphate solution, 0.66 mg of silver got into the solution, which was 47% of silver applied on the filter during the antimicrobial treatment.

#### Discussion

The results of recent research work have demonstrated that bacteria are able to survive in polypropylene filters. This phenomenon was observed both in filters incubated in air of high relative humidity RH (80%, 70%) and in those working in humidity typical HVAC system (RH 40% - 45%). The results of the present research work indicated that gram-positive, non sporulating bacteria, *M. luteus*, survived in the air filters and retained the ability to multiply (Figure 4). The number of viable cells was at the stable level of 10<sup>5</sup> cfu/cm<sup>2</sup> throughout the whole time of the experiment (11 days). In the case of the other three strains, both sporulating (*B. subtilis*) and non sporulating (*M. roseus*, *P. putida*), the number of viable cells in the time of incubation (34 days) decreased and stabilised at the level 10<sup>1</sup> cfu/cm<sup>2</sup> (*P. putida*) - 10<sup>3</sup> cfu/cm<sup>2</sup> (*B. subtilis*) - Figure 5. The number of viable cells of *M. roseus* tended to decrease constantly, reaching 10<sup>2</sup> cfu/cm<sup>2</sup>

on the last day of the experiment. The largest decrease was noticed in the case of *M. roseus* cells (99.9%), and the lowest for *B. subtilis* (86.9%). Maus et al. (1997) demonstrated that the viability of gram-negative rods, *Escherichia coli*, after 1 h incubation in RH 30 - 60% decreased to 20%. In the case of gram-positive *M. luteus*, the viability remained very high, 95 - 100%. The authors emphasised that the differences in viability between *E. coli* and *M. luteus* are related to their morphology. Gram-positive bacteria are more resistant to environmental stresses like dehydration or the toxic effect of oxygen. Similar results were obtained by Maus et al. [9]. They noticed that after 5 days of incubation the number of *B. subtilis* spores remained stable in filters exposed to air flow when RH = 20 - 98%.

The presence of an antimicrobial compound (AgNO<sub>3</sub>) in the air filters caused a decrease in the amount of bacteria (Figure 7), which was observed in the case of both gram-negative and gram-positive strains. The addition of AgNO<sub>3</sub> at a concentration of 1.4 × 10<sup>-6</sup> M resulted in a reduction in the amount of bacteria from 42.1% (*M. roseus*) and 94.7% (*B. subtilis*) to 98.7% (*P. luteola*) within 2 days. After 7 days the three test strains were not detectable in the filter media. *M. luteus* survived in the filters during the whole time of the experiment, (11 days) although its amount significantly decreased (Figure 6). In the unused and untreated filters, a very high reduction in the amount of bacteria was observed but not before the 34<sup>th</sup> day. Similar results were presented by Matsumura et al [10], in which they highlighted the antimicrobial activity of AgNO<sub>3</sub> at a concentration of 1.0 × 10<sup>-6</sup> M against

*E. coli* - gram-negative rods. Feng et al. [11] proved the inhibiting influence of AgNO<sub>3</sub> on both *E. coli* and gram-positive bacteria - *S. aureus* [12]. The results of their experiments confirmed that gram-positive bacteria, thanks to the thick peptidoglycan layer in the cell wall, are less susceptible to silver ion penetration in the cytoplasm.

Verdenelli et al [13] and Cecchini et al [14] studied bacterial growth in High Efficiency Particulate Air Filters (HEPA, class H13 and H14) treated with antimicrobial factors. They used phosphated quaternary amine complexes incorporated in filter media during the production cycle. It was found out that the chemicals inhibited microbial growth within 14 days of incubation, while untreated filters were colonised by both bacteria and fungi within 7 days [14]. The study by Verdenelli et al. [13] resulted in a finding that antimicrobial filter treatment not only inhibits microbial growth but also, as a consequence, preserves the filter's integrity, thereby reducing bacterial emission into treated air. They also found that the longer the working time of the filters, the weaker the activity of the antimicrobial compound. Moreover, Cecchini et al [14] observed that the antimicrobial activity of the agents may change after their incorporation in the filter media.

In the present research work, silver emission from filtering material was established. The silver concentration in the air surrounding the incubation column reached 0.00034 mg/(l·h). The problem is probably caused by the agglomeration of silver nitrate particles on the surface of the filter and, in consequence, their blow-out into the surrounding air. For this reason the more effective seems to be the

addition of an antimicrobial agent during the production cycle or the application of silver nanoparticles, which were proved not to be emitted into air, have low volatility, high thermal stability and low toxicity to human cells [12]. Such technology is being introduced by leading air filter and HVAC system producers. There have also been attempts, which met with success, to use silver nanoparticles as an antibacterial agent incorporated into textile fabrics or even polyurethane foam [12, 15]. Unlike silver ions, silver nanoparticles are proved to be 1.4 to 1.9× stronger than silver ions and inhibit the growth of such pathogenic microorganisms as *S. aureus*, *Vibrio cholerae* and *Salmonella typhi* [12]. However, the application of antimicrobial agents containing silver ions in medicine ( $\text{Ag}^+$ ) has led to silver-resistant bacteria evolution. This phenomenon was described in the case of *E. coli* and *Enterococcus hirae*. Interestingly, the transport of  $\text{Ag}^+$  in *E. hirae* cells was possible thanks to copper-effluxing ATP-ase CopB, which is responsible for copper ion,  $\text{Cu}^+$ , removal. The  $K_m$  of both substrates ( $\text{Ag}^+$  and  $\text{Cu}^+$ ) turned out to be identical [16]. Considering the fact that silver resistance may not require special enzyme production and that the plasmids with genes determining the resistance may be transferred in the bacterial population, the ability to survive in the presence of silver particles may become widespread.

## ■ Summary

This study shows that the addition of antibacterial agents to filters is effective in preventing bacteria from colonising filters. The clear reduction in living bacterial cells in silver treated filters makes the technology of antimicrobial filter treatment really necessary for the future. However, it is apparent that the ability of microbial adaptation is a challenge for scientists and manufacturers.



## References

- Hugenholtz P., Fuerst J. A.; Heterotrophic bacteria in air-handling system. *Appl Environ Microbiol*, Vol. 58, 1992 pp. 3914-3920.
- Martiny H., Möritz M., Rüdén H.; Deposit of bacteria and fungi in different materials of air conditioning systems. *Proceedings of the International Symposium on Control, Yokohama 1994*, pp. 271-274.
- Neumeister H. G., Kemp P. C., Kircheis U., Schleibinger A., Ruden P.; Fungal growth on air filtration media in heating ventilation and air conditioning systems. In: *Proceedings of Healthy Buildings IAQ '97 Global Issues and regional Solutions, ASHRAE Annual; IAQ Conference and ISIAQ Fifth International Conference on Health Buildings, Washington DS, USA, Vol. 1, 1997 pp. 569-574.*
- Charkowska A. HVAC system contamination and its removal. *Problems of indoor air quality in Poland' 99 (in Polish). Conference proceedings 2000*, pp.19-37.
- Kemp P. C., Neumeister-Kemp H. G., Lysek G., Murray F.; Survival and growth of microorganisms on air filtration media during initial loading. *Atmos Environ*, Vol. 35, 2001 pp. 4739-4749.
- Maus, R., Goppelsröder, A., Umhauer, H. Survival of bacterial and mold spores in air filter media. *Atmos Environ*, Vol. 35, 2001 pp. 105-113.
- Zyska B.; Microbiological disasters, failures and dangers in industry and building (in Polish). Technical University of Lodz, 2001.
- Lacey J., Dutkiewicz J.; Bioaerosols and occupational lung disease. *J Aerosol Sci*, Vol. 25, 1994 pp. 1371-1404.
- Maus R., Goppelsröder A., Umhauer H.; Survival of bacteria in filter media. *Atmos Environ*, Vol. 31, 1997 pp. 2305-2310.
- Matsumura Y., Yoshikata K., Kunisaki S. I., Tsuchido T.; Mode of bacterial action of silver zeolite and its comparison with that of silver nitrate. *Appl Environ Microb*, Vol. 69 (7), 2003 pp. 4278-81.
- Feng Q. L., Wu J., Chen G. Q., Cui F. Z., Kim T. N., Kim J. O.; A mechanistic study of the antibacterial effect of silver ions on *Escherichia coli* and *Staphylococcus aureus*. *J Biomed Mater*, Vol. 52 (4), 2000 pp. 662-668.
- Rai M., Yadav A., Gade A.; Silver nanoparticles as a new generation of antimicrobials. *Biotechnol Adv*, Vol. 27, 2009 pp. 76-83.
- Verdenelli M. C., Cecchini C., Orpianesi C., Dadea G. M., Cresci A.; Efficacy of antimicrobial filter treatments on microbial colonization of air panel filters. *J Appl Microbiol*, Vol. 94, 2003 pp. 9-15.
- Cecchini C., Verdenelli M. C., Orpianesi C., Dadea G. M., Cresci A.; Effect of antimicrobial treatment on fibreglass-acrylic filters. *J Appl Microbiol*, Vol. 97, 2004 pp. 371-377.
- Jain P., Pradeep T.; Potential of silver nanoparticle-coated polyurethane foam as an antibacterial water filter. *Biotechnol Bioeng*, Vol. 90 (1), 2005 pp. 59-63.
- Nies D. H.; Microbial heavy-metal resistance. *Appl Microbiol Biot*, Vol. 51, 1999 pp. 730-750.

■ Received 08.01.2010      Reviewed 18.03.2010



## Institute of Biopolymers and Chemical Fibres

*FIBRES &  
TEXTILES  
in Eastern  
Europe  
reaches all  
corners of the  
world!  
It pays to  
advertise your  
products  
and services in  
our magazine!  
We'll gladly  
assist you in  
placing your  
ads.*

### FIBRES & TEXTILES in Eastern Europe

ul. Skłodowskiej-Curie 19/27  
90-570 Łódź, Poland

Tel.: (48-42) 638-03-00  
637-65-10

Fax: (48-42) 637-65-01

e-mail:

[ibwch@ibwch.lodz.pl](mailto:ibwch@ibwch.lodz.pl)

[infor@ibwch.lodz.pl](mailto:infor@ibwch.lodz.pl)

Internet:

<http://www.fibtex.lodz.pl>